



SWA Water Australia
Water & Waste Water Engineers



SWA OIL SEPARATOR COMMERCIAL RANGE

SWA WATER AUSTRALIA designs, manufactures and constructs industrial waste water treatment plants and manufactures industrial Oil Separators, Solids Separators & DAF units. In recent years companies within the SWA Water Group of Companies have manufactured hundreds of Oil Separators, Solids Separators & DAF units. These projects range from very small separators for workshops and service stations to large oil refineries; from small food processing plants to large abattoirs.

SWA has three sizes in the Commercial Range of CPI style gravity flow Oil Separators.

- SWA-CC1500 1500lph
- SWA-CC3000 3000lph
- SWA-CC5000 5000lph

INDUSTRIAL RANGE of Oil Separators are available for flow rates from 10 m³/hr to 500 m³/hr



SWA CC1500 Oil Separator



SWA CC3000 Oil Separator



SWA CC5000 Oil Separator
Design with integral waste oil tank, pump and control panel.



SWA CC5000 Oil Separator

Material available includes:

- Standard material SS304
- Alternative material:
 - SS316
 - Duplex stainless steel
 - Super duplex stainless steel

SWA Oil Separator commercial range at a glance:

- Treated effluent free oil content < 10 mg/l standard
- Separators also available for < 5mg/l treated effluent free oil content.
- No moving parts within the oil separator
- Small Footprint
- Low maintenance, low operating cost, high efficiency
- Chemical and thermal emulsion breaking units available
- Pilot Plants available
- Stainless steel construction - long life, no corrosion problems

SWA commercial range oil separator is ideal for:

- Work shops
- Car washes
- Panel beaters
- Service stations
- Transformer yards
- Heavy duty washing

WATER & WASTE WATER ENGINEERS PROCESS DESIGN & CONTROL

SWA's Oil Water Separators are CPI style parallel plate gravity oil separators designed to separate oil droplets larger than 50 micron.
(For SG oil < 0.90 and T > 20°C)

The “standard package” includes:

- Oil Separator (CC1500, CC3000 or CC5000)
- Control Panel
- Ball float
- Delivery Pump



1. SWA Oil Separator:

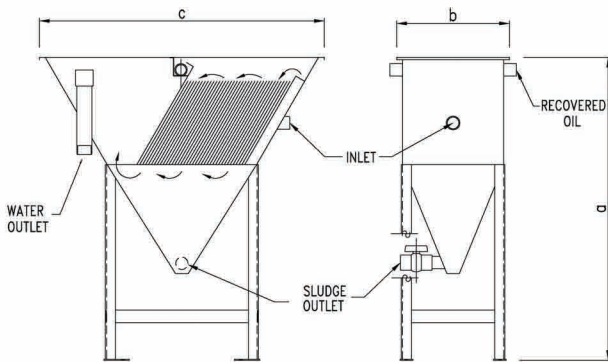

MODEL	FLOWRATE	a mm	b mm	c mm
SWA-CC1500	1500 lph	1200	446	1130
SWA-CC3000	3000 lph	1200	848	1130
SWA-CC5000	5000 lph	1200	848	1467

2. Pump:

ASM non-emulsifying diaphragm pump

MODEL		ASM PUMP	
		1 PHASE	3 PHASE
1	SWA-CC1500	DS25	DT25
2	SWA-CC3000	DS32	DT32
3	SWA-CC5000	DS38	DT38



3. Control Panel:

- Manufactured by SWA
- Cubicle: polycarbonate
- Type: Form I
- Rating: IP55
- Single phase or three phase
- Relay logic
- Standard inclusions

SWA WATER AUSTRALIA Pty. Ltd
www.swawater.com.au A.B.N. 88 122 967 060

Unit 3, 74-76 Captain Cook Dr. Caringbah, NSW 2229 Australia
PO Box 2699 Taren Point SYDNEY NSW 2229
Tel: (61 2) 9525 4788
Fax: (61 2) 9526 2795
Email: sales@swawater.com.au