



SWA Water Australia
Water & Waste Water Engineers



SWA SOLIDS SEPARATORS

SWA WATER AUSTRALIA designs, manufactures and constructs industrial waste water treatment plants and manufactures industrial oil separators, solids separators & DAF units. In recent years companies within the SWA Water Group of Companies have manufactured hundreds of Oil Separators, solids separators & DAF units. These projects range from very small separators for workshops and service stations to large oil refineries; from small food processing plants to large abattoirs. SWA has a range of Solids (plate) Separators used for removing settleable suspended solids from water. Plate pack configurations include up flow, down flow and cross flow arrangements.



SWA CCS-10 Solids Separator 10cu.m/hr

Materials available include:

Tank body:

- Epoxy painted carbon steel
- Stainless steel SS304 or SS316
- Duplex or super duplex stainless steel tank bodies
- Concrete tank bodies (constructed on site) - large units only

Plate packs:

- GRP
- Stainless steel SS304, SS306, duplex st.st. or super duplex



SWA CCS-10 Solids Separator 10cu.m/hr



SWA CCS-5 Solids Separator 5cu.m/hr



SWA CCS-5 Solids Separator 5cu.m/hr

SWA Solids Separator Range:

- Cross flow separators
- Up flow separators
- Down flow separators

SWA Solids Separator at a glance:

- Compact process requiring less space
- Factory made units from 1 m³/h up to 250 m³/h
- Larger units constructed on site or multiple units
- Plate packs are easily removed for inspection or cleaning
- <5 mg/l solid content in treated effluent
- Inclined plate pack prevents solids build-up
- Design flexibility
- No moving parts; no spare parts required
- Wide range of applications
- Full treatment system integration
- Integrated reaction tanks available

WATER & WASTE WATER ENGINEERS

PROCESS DESIGN & CONTROL

What makes SWA's Solids Separator better than others?

Conservative design, selection of superior materials and equipment plus many subtle features make SWA's Solids Separator extremely reliable, consistent in performance and user friendly for operation & maintenance.

The "little things" which make a good Solids Separator into a "fantastic" Solids Separator include easy to drain and clean tank; flexible customised options; galvanised support steel frame; no moving parts within the unit; long life, low operation cost and high efficiency.

All of these features make SWA's Solids Separator stand out from the rest.

SWA Solids Separators For:

- Construction site
- Electroplating
- Coal washing
- Coal handling
- Heavy duty truck wash
- Mining
- Anodiser

Customising options include:

- Choice of material for both tank body and plate packs
- Integral reaction tanks
- Walkways and access steps/ladders
- Sludge thickening and dewatering
- Skid mounted with control panels

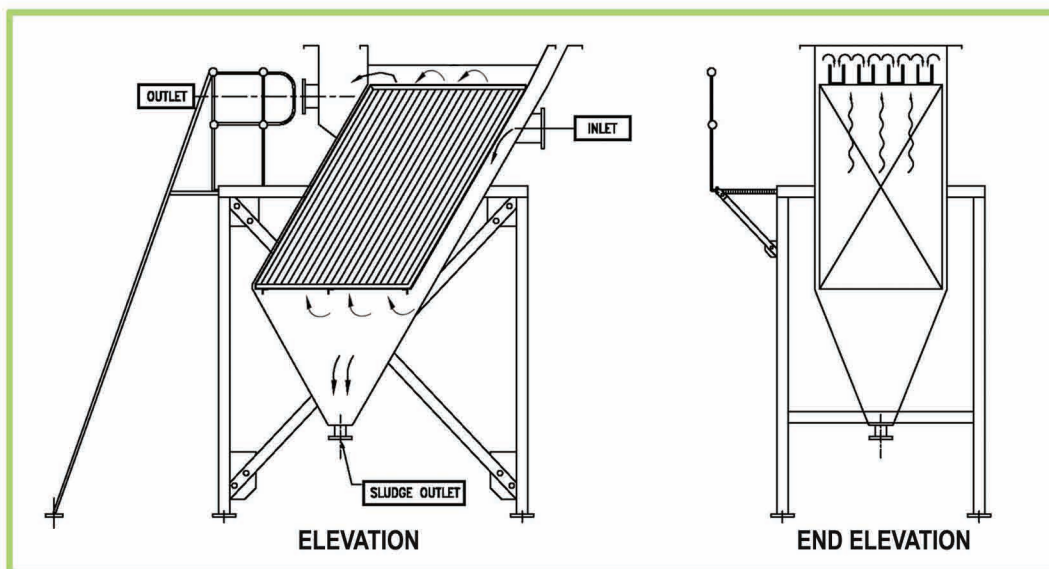
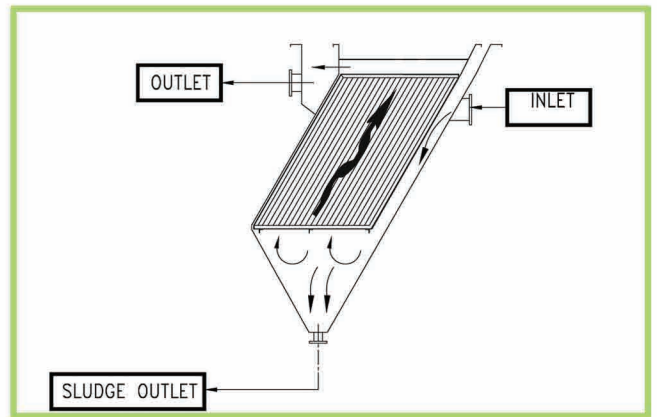
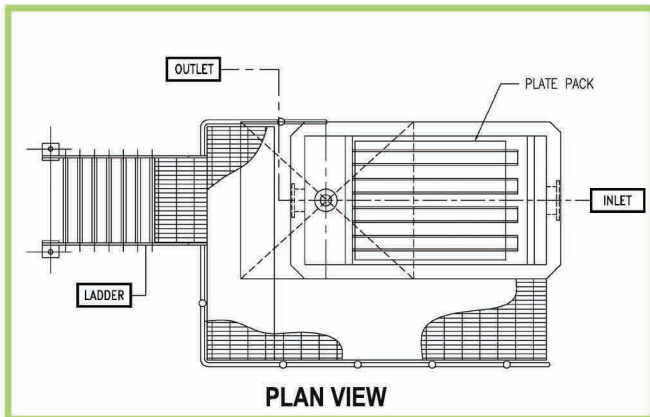

SWA WATER AUSTRALIA Pty. Ltd
www.swawater.com.au A.B.N. 88 122 967 060

Unit 3, 74-76 Captain Cook Dr. Caringbah, NSW 2229 Australia
PO Box 2699 Taren Point SYDNEY NSW 2229
Tel: (61 2) 9525 4788
Fax: (61 2) 9526 2795
Email: sales@swawater.com.au